

POLITECNICO DI TORINO

ESAME DI STATO – I SESSIONE ANNO 2009

SETTORE CIVILE - AMBIENTALE SEZIONE A – Classe 38/S

Tema n. 1

ESCAVAZIONE DI ARGILLA PER LATERIZI

Nell'area A indicata sulla planimetria della Figura 1 allegata è consentito aprire una cava di argilla per alimentare una fabbrica di laterizi, alle seguenti condizioni:

- Solo il materiale a quota superiore a + 420 m s.l.m. può essere asportato;
- Il suolo di copertura, inutilizzabile per la produzione per uno spessore medio di 70 cm, dev'essere riportato sull'area sfruttata;
- Al termine dello sfruttamento, la pendenza delle scarpate residue contornanti l'area sfruttata non dovrà superare il 20%;

La planimetria e le sezioni della Figura 2 allegata descrivono la situazione finale desiderata.

L'argilla e la copertura sono di facile escavazione; la loro massa volumica in posto è di circa 1800 kg/m³; non sono presenti nell'area ruderi, massi, ceppi o altri ostacoli particolari.

La fabbrica ha un fabbisogno annuo di 150000 t di argilla ed intende soddisfarlo unicamente con la produzione della cava in questione. Per motivi climatici si prevede di poter lavorare nella cava 150 giorni/anno, un turno al giorno.

Lo stabilimento dista in media 1200 m dalla cava, ed è collegato all'area di estrazione da una strada sterrata idonea al transito dei mezzi di cantiere; adiacente allo stabilimento esiste un'area di stoccaggio sufficiente a costruirvi un polmone di materiale escavato per sopperire ai periodi di fermo cava. La strada è in piano ed in buone condizioni.

Quanto ai mezzi di scavo, l'esercente intende valutare, sia per la scopertura e lo stendimento dello strato superficiale, sia per lo scavo ed il trasporto a stock dell'argilla, le seguenti opzioni:

- 1: uno o più motoscraper
- 2: dozer, pala caricatrice gommata, dumper
- 3: dozer, escavatore frontale, dumper

QUESITI

1. Avendo individuato, con le necessarie motivazioni, l'opzione che s'intende adottare, descriverne le modalità di attuazione, discutendone pregi e difetti rispetto alle altre alternative (con riferimento allo specifico caso descritto);
2. Suggestire, con l'aiuto anche di schizzi esplicativi, un plausibile programma di scavo, indicando le aree da sfruttare e risistemare successivamente, anno per anno, e le direzioni di scavo, tenuti presenti i fabbisogni della fabbrica e la necessità di accelerare la restituzione dell'area all'impiego agricolo;
3. Individuare, sulla base dei dati tecnici sulle macchine disponibili, tipo e numero di macchine necessarie all'operazione;
4. Verificare che, con la soluzione prescelta, la produttività del cantiere sia soddisfatta.

100 m

Scala 1:10.000



Figura 1. Planimetria della zona



Sez. A-B

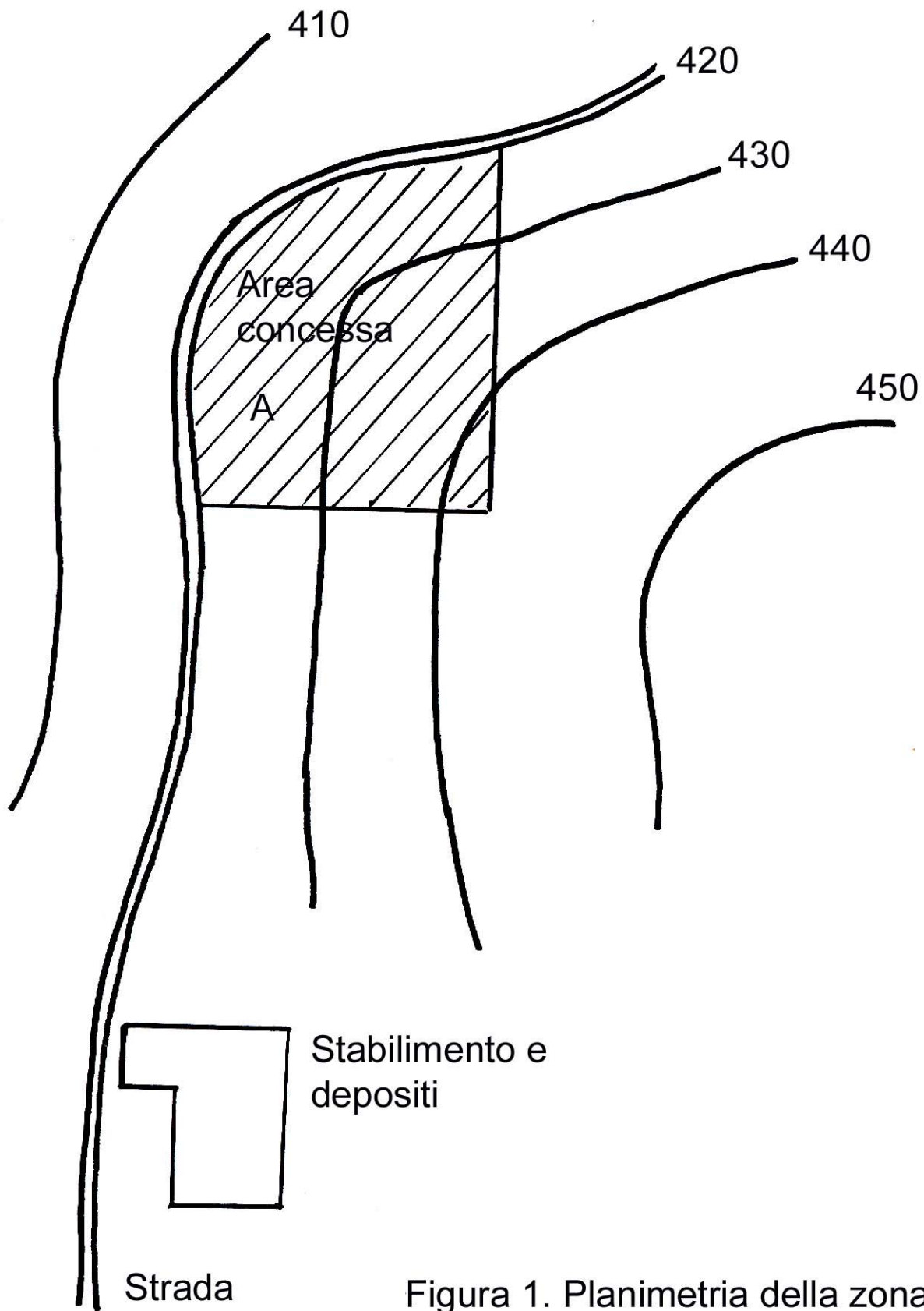
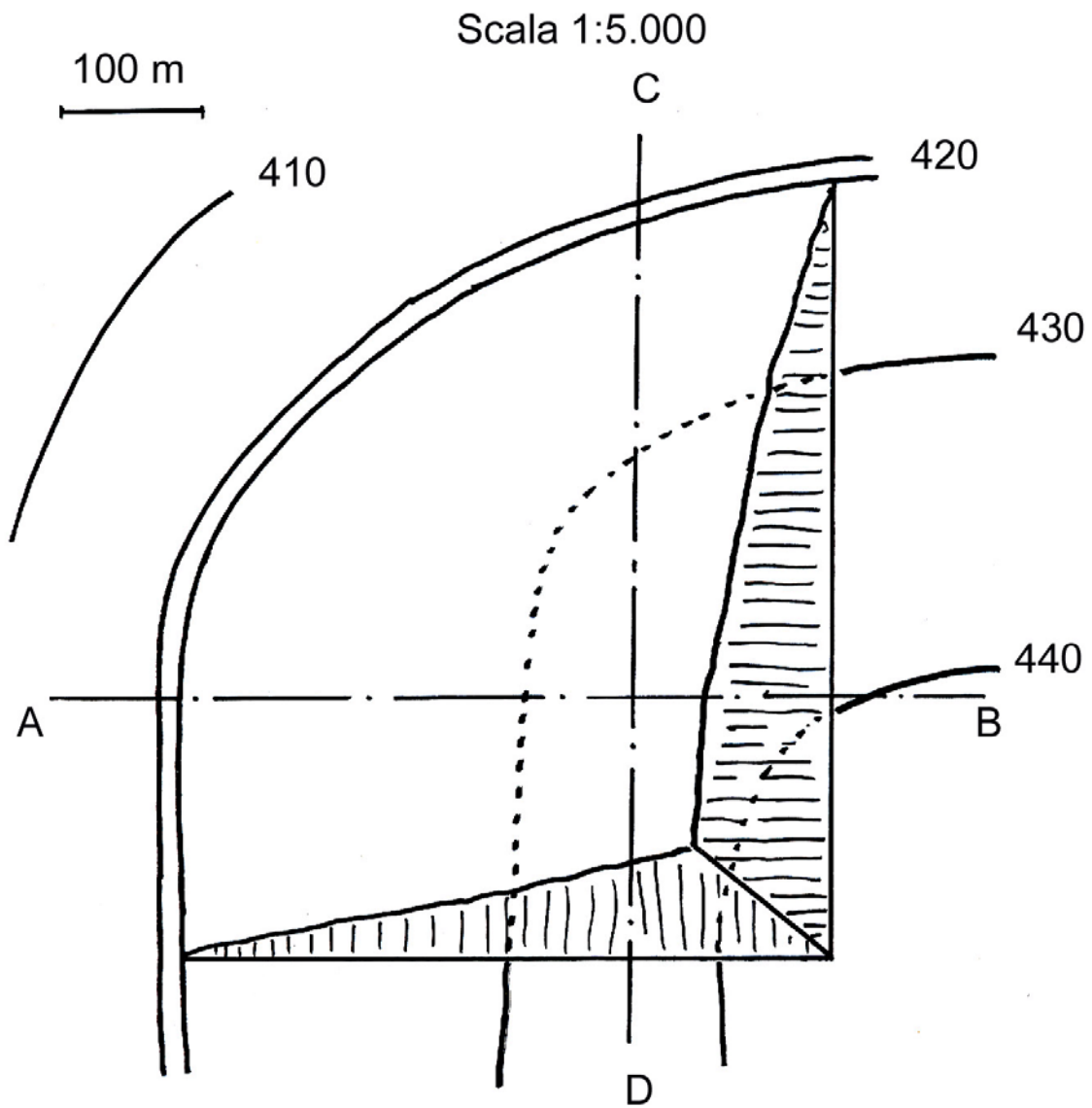

Sez. C-D



Figura 2. Situazione finale dell'area dopo sfruttamento

Wheel Tractor-Scrapers

Specifications • Standard Scrapers



MODEL	611		621G		631E Series II		651E	
Flywheel Power	197 kW	265 hp	246/272 kW	330/365 hp	335/365 kW	450/490 hp	410/452 kW	550/605 hp
Approx. Operating Weight (Empty)▲	23 900 kg	52,640 lb	32 250 kg	71,090 lb	44 210 kg	97,460 lb	61 130 kg	134,760 lb
Scraper Capacity: Striped	8 m ³	10.5 yd ³	10.7 m ³	14 yd ³	16.1 m ³	21 yd ³	24.5 m ³	32 yd ³
Heaped	11 m ³	15 yd ³	15.3 m ³	20 yd ³	23.7 m ³	31 yd ³	33.6 m ³	44 yd ³
Rated Load	16 340 kg	36,000 lb	21 770 kg	48,000 lb	34 020 kg	75,000 lb	47 175 kg	104,000 lb
Weight Distribution — Empty								
Drive	66%		68%		67%		66%	
Rear	34%		32%		33%		34%	
Weight Distribution — Loaded								
Drive	51%		53%		53%		53%	
Rear	49%		47%		47%		47%	
Engine Model	3306T		3406ETA		3408ETA		3412ETA	
Rated Engine RPM	2200		1800		2000		1900	
Displacement	10.5 L	638 in ³	14.6 L	893 in ³	18 L	1099 in ³	27 L	1649 in ³
Top Speed (Loaded)	44.4 km/h	27.6 mph	51 km/h	32 mph	53 km/h	33 mph	53 km/h	33 mph
180° Curb-to-Curb Turning Width	10.2 m	33'5"	11.7 m	38'5"	12.2 m	40'1"	13.6 m	44'7"
With ROPS Restriction	—		—		—		14.5 m	47'7"
Tires — Tractor Drive	29.5R25 [□] L3		33.25R29 [□] E2/E3		37.25R35 [□] E2/E3		40.5/75R39	
Scraper	29.5R25 [□] L		33.25R29 [□] E2/E3		37.25R35 [□] E2/E3		40.5/75R39	
Width of Cut	2.903 m	9'6"	3.02 m	9'11"	3.51 m	11'6"	3.85 m	12'8"
Maximum Depth of Cut	353 mm	13.9"	333 mm	13.1"	437 mm	17.2"	440 mm	17.3"
Maximum Depth of Spread	376 mm	14.8"	522 mm	20.6"	480 mm	18.9"	660 mm	26"
Fuel Tank Refill Capacity	580 L	153 U.S. gal	606 L	160 U.S. gal	814 L	215 U.S. gal	954 L	252 U.S. gal
GENERAL DIMENSIONS:								
Height to Top of Scraper	3.24 m	10'8"	3.71 m	12'2"	4.29 m	14'1"	4.71 m	15'5"
Wheelbase	7.06 m	23'2"	7.72 m	25'4"	8.77 m	28'9"	9.97 m	32'9"
Overall Length	12.02 m	39'5"	12.93 m	42'5"	14.56 m	47'9"	16.18 m	53'1"
Overall Width	3.27 m	10'9"	3.47 m	11'4"	3.94 m	12'11"	4.35 m	14'4"
Shipping Width (Draft Arm on Inside of Bowl)	—		—		3.64 m	11'11"	3.91 m	12'10"
Scraper Tread	2.06 m	6'9"	2.18 m	7'2"	2.46 m	8'1"	2.81 m	9'3"
Tractor Tread	2.06 m	6'9"	2.20 m	7'3"	2.46 m	8'1"	2.84 m	8'8"

▲ Operating weight includes standard machine, coolant, lubricants, full fuel tank, and operator.

Wheel Tractor Scraper 611

DISTANCE vs. PRODUCTION

CONDITIONS: Flat haul. Percentages shown are rolling resistance only. 100% efficiency (60 min hour).

- Material: 1780 kg/m³ (3000 lb/yd³).
- Payload: 16 344 kg, 8.8 Bm³ (36,000 lb, 12 BCY).
- Empty weight: 23 900 kg (52,640 lb).
- Fixed time: 1.2 min.

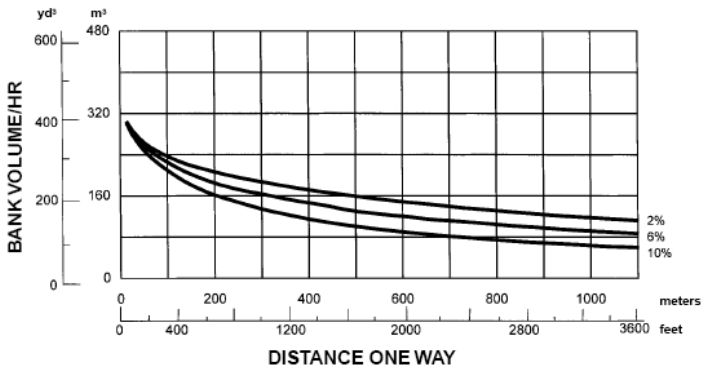

Wheel Tractor Scraper 621G

DISTANCE vs. PRODUCTION

CONDITIONS: Flat haul. Percentages shown are rolling resistance only. 100% efficiency (60 min hour).

- Material: 1780 kg/m³ (3000 lb/yd³).
- Payload: 21 770 kg, 12.2 Bm³ (48,000 lb, 16 BCY).
- Empty weight: 32 250 kg (71,090 lb).
- Fixed time: 1.2 min.

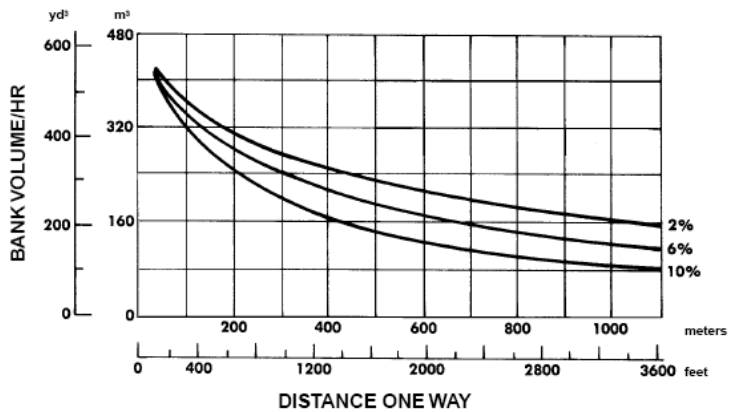

Wheel Tractor Scraper 631E Series II

DISTANCE vs. PRODUCTION

CONDITIONS: Flat haul. Percentages shown are rolling resistance only. 100% efficiency (60 min hour).

- Material: 1780 kg/m³ (3000 lb/yd³).
- Payload: 34 020 kg, 19.1 Bm³ (75,000 lb, 25 BCY).
- Empty weight: 44 210 kg (97,460 lb).
- Fixed time: 1.3 min.

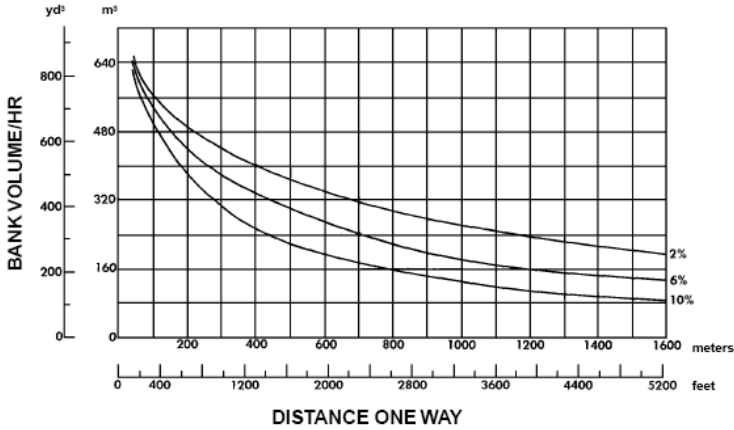

Wheel Tractor Scraper 651E

DISTANCE vs. PRODUCTION

CONDITIONS: Flat haul. Percentages shown are rolling resistance only. 100% efficiency (60 min hour).

- Material: 1780 kg/m³ (3000 lb/yd³).
- Payload: 47 175 kg, 26.5 Bm³ (104,000 lb, 34.6 BCY).
- Empty weight: 61 130 kg (134,760 lb).
- Fixed time: 1.3 min.

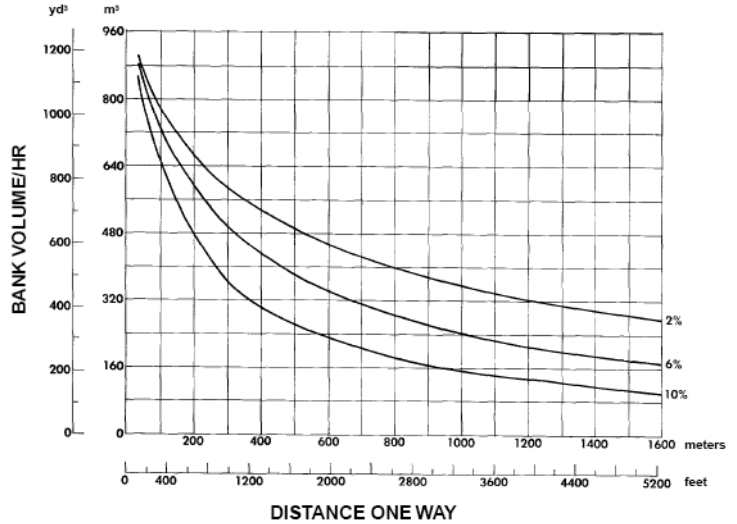

TYPICAL ROLLING RESISTANCE FACTORS

Various tire sizes and inflation pressures will greatly reduce or increase the rolling resistance. The values in this table are approximate, particularly for the track and track + tire machines. These values can be used for estimating purposes when specific performance information on particular equipment and given soil conditions is not available. See Mining and Earthmoving Section for more detail.

UNDERFOOTING	ROLLING RESISTANCE, PERCENT*			
	Tires Bias	Tires Radial	Track **	Track +Tires
A very hard, smooth roadway, concrete, cold asphalt or dirt surface, no penetration or flexing	1.5%*	1.2%	0%	1.0%
A hard, smooth, stabilized surfaced roadway without penetration under load, watered, maintained	2.0%	1.7%	0%	1.2%
A firm, smooth, rolling roadway with dirt or light surfacing, flexing slightly under load or undulating, maintained fairly regularly, watered	3.0%	2.5%	0%	1.8%
A dirt roadway, rutted or flexing under load, little maintenance, no water, 25 mm (1") tire penetration or flexing	4.0%	4.0%	0%	2.4%
A dirt roadway, rutted or flexing under load, little maintenance, no water, 50 mm (2") tire penetration or flexing	5.0%	5.0%	0%	3.0%
Rutted dirt roadway, soft under travel, no maintenance, no stabilization, 100 mm (4") tire penetration or flexing	8.0%	8.0%	0%	4.8%
Loose sand or gravel	10.0%	10.0%	2%	7.0%
Rutted dirt roadway, soft under travel, no maintenance, no stabilization, 200 mm (8") tire penetration and flexing	14.0%	14.0%	5%	10.0%
Very soft, muddy, rutted roadway, 300 mm (12") tire penetration, no flexing	20.0%	20.0%	8%	15.0%

*Percent of combined machine weight.

**Assumes drag load has been subtracted to give Drawbar Pull for good to moderate conditions. Some resistance added for very soft conditions.

Construction & Mining Trucks | Specifications



MODEL	769D		771D		775D	
Body Type	Dual Slope		Quarry		Quarry	
Gross Vehicle Weight	68 180 kg	150,000 lb	73 970 kg	163,100 lb	106 590 kg	235,000 lb
Chassis Weight*	22 950 kg	50,600 lb	22 950 kg	50,600 lb	30 390 kg	67,000 lb
Body Weight	7330 kg	16,170 lb	10 350 kg	22,820 lb	12 630 kg	28,230 lb
Maximum Payload**	37 900 kg	83,570 lb	40 670 kg	89,680 lb	63 370 kg	139,730 lb
Standard Liner Weight	3160 kg	6970 lb	—	—	—	—
Payload with Standard Liner	34 740 kg	76,600 lb	—	—	—	—
Capacity:						
Struck (SAE)	17 m ³	22.2 yd ³	20.2 m ³	26.4 yd ³	31.4 m ³	41.1 yd ³
Heaped (2:1) (SAE)	24.2 m ³	31.7 yd ³	27.5 m ³	36 yd ³	41.5 m ³	54.3 yd ³
Distribution Empty:						
Front		49.8%		46.3%		44.3%
Rear		50.2%		53.7%		55.7%
Distribution Loaded:						
Front		33.3%		32.9%		31.2%
Rear		66.7%		67.1%		68.8%
Engine Model	3408E TA		3408E TA		3412E TA	
Number of Cylinders	8		8		12	
Bore	137 mm	5.4"	137 mm	5.4"	137 mm	5.4"
Stroke	152 mm	6"	152 mm	6"	152 mm	6"
Displacement	18 L	1099 in ³	18 L	1099 in ³	27 L	1649 in ³
Flywheel Power	362 kW	485 hp	362 kW	485 hp	517 kW	693 hp
Gross Power	380 kW	510 hp	380 kW	510 hp	541 kW	725 hp
Standard Tires	18.00R33 (E-4)		18.00R33 (E-4)		24.00R35 (E-4)	
Machine Clearance Turning Circle	19.8 m	65'0"	19.8 m	65'0"	24 m	78'9"
Fuel Tank Refill Capacity	530 L	140 U.S. gal	530 L	140 U.S. gal	700 L	185 U.S. gal
Top Speed (Loaded)	75 km/h	47 mph	56 km/h	35 mph	66 km/h	41 mph
GENERAL DIMENSIONS (Empty):						
Height to Canopy Rock Guard Rail	4.00 m	13'1"	3.80 m	12'6"	4.41 m	14'5"
Wheelbase	3.70 m	12'2"	3.70 m	12'2"	4.19 m	13'9"
Overall Length	7.40 m	24'5"	7.60 m	25'0"	9.70 m	31'10"
Loading Height (Empty)	3.10 m	10'4"	3.40 m	11'2"	3.91 m	12'10"
Height at Full Dump	7.70 m	25'4"	7.70 m	25'3"	8.80 m	28'10"
Body Length (Target Length)	5.24 m	17'2"	5.41 m	17'9"	6.54 m	21'5"
Width (Operating)	5.01 m	16'5"	5.01 m	16'5"	5.21 m	17'1"
Width (Shipping)***	3.91 m	12'10"	3.99 m	13'1"	3.97 m	13'0"
Front Tire Tread	3.10 m	10'2"	3.10 m	10'2"	3.28 m	10'9"

*Weights include lubricants, coolants, and 10% fuel.
 **Maximum rating requires selection of proper tires and is dependent on selection of optional equipment. Gross vehicle weight should not be exceeded.
 ***Disassembled.

769D Travel Time | Construction & Mining Trucks
 • 18.00R33 Tires

LOADED

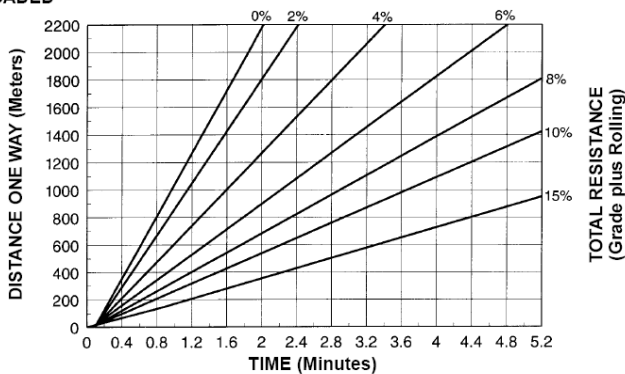

EMPTY

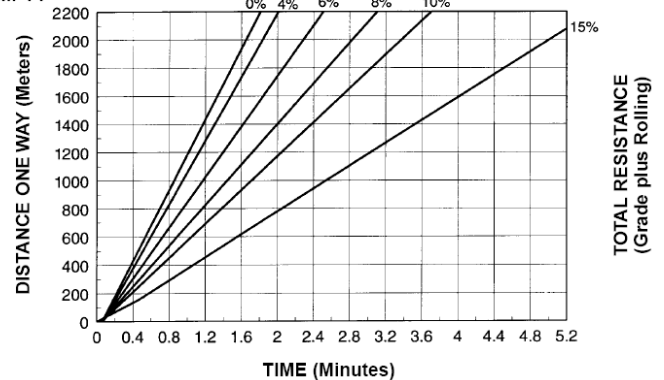

771D Travel Time
 • 18.00R33 Tires
 Construction & Mining Truck

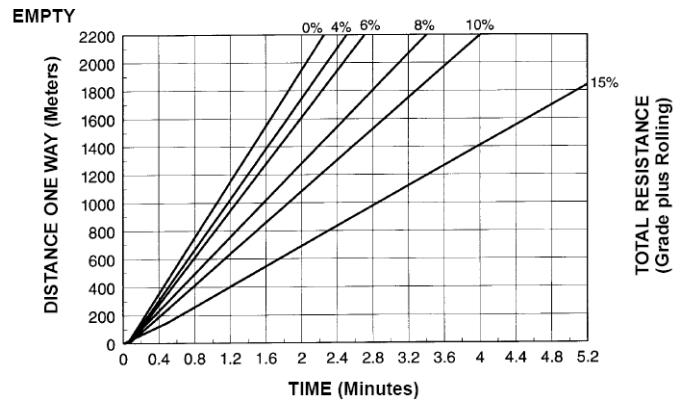
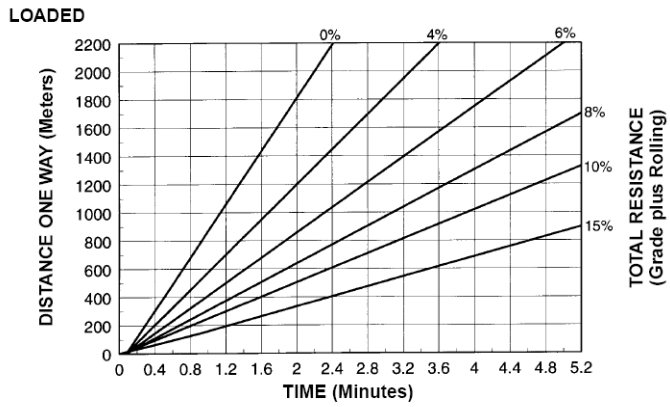

Construction & Mining Trucks
 775D Travel Time
 • 24.00R35 Tires

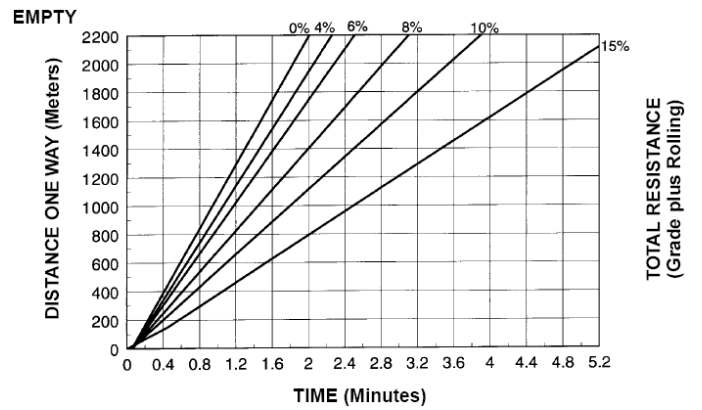
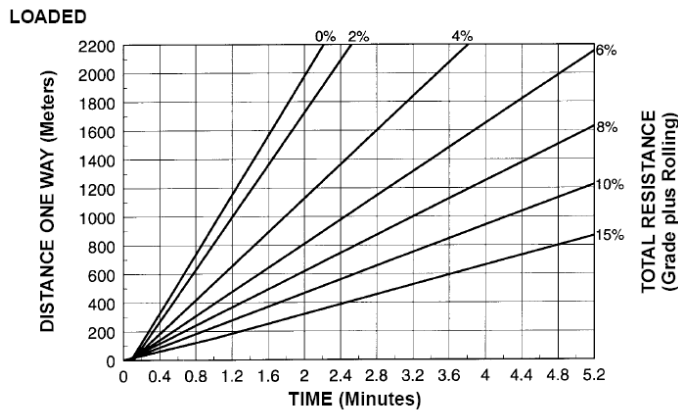

Front Shovels | Specifications



MODEL	5080		5130B		5230	
Sourcing	U.S.		U.S.		U.S.	
Flywheel Horsepower	319 kW	428 hp	597 kW	800 hp	1095 kW	1470 hp
Operating Weight*	83 800 kg	184,600 lb	181 000 kg	399,000 lb	318 500 kg	702,000 lb
Bucket Capacity Range (heaped)	5.2 m ³	6.8 yd ³	9-11 m ³	12.0-14.5 yd ³	12.5-17 m ³	16.3-22.2 yd ³
Engine Model	3406C ATAAC		3508B EUI		3516 EUI	
Rated Engine RPM	1800		1750		1750	
No. of Cylinders	6		8		16	
Bore	137 mm	5.4"	170 mm	6.7"	170 mm	6.7"
Stroke	165 mm	6.5"	190 mm	7.5"	190 mm	7.5"
Displacement	14.6 L	891 in ³	34.5 L	2105 in ³	69.1 L	4211 in ³
Max. Hydraulic Pump Output at Rated RPM: Implement	2 × 430 L/min	2 × 114 gpm	4 × 372 L/min	4 × 99 gpm	6 × 372 L/min	6 × 99 gpm
Swing	1 × 340 L/min	1 × 90 gpm	1 × 464 L/min	1 × 123 gpm	2 × 464 L/min	2 × 123 gpm
Relief Valve Settings:						
Implement Circuits	31 400 kPa	4550 psi	31 000 kPa	4500 psi	31 000 kPa	4500 psi
Travel Circuits	34 300 kPa	4980 psi	35 000 kPa	5080 psi	35 000 kPa	5080 psi
Pilot Circuits	3500 kPa	505 psi	4000 kPa	580 psi	4000 kPa	580 psi
Maximum Drawbar Pull	546 kN	122,850 lb	872 kN	196,000 lb	1545 kN	340,875 lb
Maximum Travel Speed at Rated RPM	Low: 2.7 km/h High: 4.4 km/h	1.7 mph 2.7 mph	3.3 km/h	2.1 mph	2.5 km/h	1.6 mph
Overall Track Length**	4.6 m	15'1"	5.55 m	18'3"	6.26 m	20'6"
Track Gauge	3.51 m	11'6"	4.72 m	15'6"	5.12 m	17'
Grouser Height	48 mm	2"	29, 71 mm	1.1", 2.8"	15 mm	0.6"
Track Shoe Widths	610, 750 mm	24", 30"	650, 800, 1000 mm	26", 32", 39"	1100, 1300, 1500 mm	43", 51", 59"
Ground Contact Areas	6.13, 7.55 m ²	66, 81.3 ft ²	8.0, 9.8, 12.3 m ²	86.1, 105.4 ft ²	15.2, 18.0, 20.8 m ²	163.6, 193.7, 223.8 ft ²
Ground Pressures	132, 107 kPa	19.2, 16 psi	217, 178, 144 kPa	31.4, 25.8, 20.9 psi	205, 174, 153 kPa	29.7, 25.3, 22.2 psi
Fuel Tank Refill Capacity	990 L	262 U.S. gal	2600 L	687 U.S. gal	5330 L	1386 U.S. gal

*Operating weights include coolant, lubricants, full fuel tank, standard shoes, bucket, and operator.
**Track length measured from center of idler to center of sprocket.

Track-Type Tractors | Specifications



MODEL	D6R LGP		D7G		D7R		D7R XR	
Flywheel Power	138 kW	185 hp	149 kW	200 hp	171 kW	230 hp	171 kW	230 hp
Operating Weight*:								
Power Shift	20 500 kg	45,200 lb	20 094 kg	44,300 lb	24 778 kg	54,600 lb	25 193 kg	55,600 lb
Direct Drive	—	—	20 502 kg	45,200 lb	—	—	—	—
Power Shift Differential Steer	20 680 kg	45,600 lb	—	—	25 077 kg	55,300 lb	25 492 kg	56,200 lb
Engine Model	3306T		3306T		3306TA		3306TA	
Rated Engine RPM	1900		2000		2100		2100	
No. of Cylinders	6		6		6		6	
Bore	121 mm	4.75"	121 mm	4.75"	121 mm	4.75"	121 mm	4.75"
Stroke	152 mm	6"	152 mm	6"	152 mm	6"	152 mm	6"
Displacement	10.5 L	638 in ³	10.5 L	638 in ³	10.5 L	638 in ³	10.5 L	638 in ³
Track Rollers (Each Side)	8		6		7		8	
Width of Standard Track Shoe	915 mm	3'0"	508 mm	1'8"	560 mm	1'10"	610 mm	2'0"
Length of Track on Ground	3.25 m	10'8"	2.72 m	8'11"	2.89 m	9'6"	3.05 m	10'0"
Ground Contact Area (W/Std. Shoe)	5.93 m ²	9254 in ²	2.76 m ²	4280 in ²	3.24 m ²	5016 in ²	3.72 m ²	5760 in ²
Track Gauge	2.23 m	7'3"	1.98 m	6'6"	1.98 m	6'6"	1.98 m	6'6"
GENERAL DIMENSIONS:								
Height (Stripped Top)**	2.43 m	7'7"	2.27 m	7'5"	2.56 m	8'5"	2.56 m	8'5"
Height (To Top of ROPS)	3.24 m	10'5"	3.20 m	10'6"	3.35 m	10'11"	3.35 m	10'11"
Height (To Top of Cab ROPS)	3.24 m	10'5"	—	—	3.43 m	11'2"	3.43 m	11'2"
Height (To Top of ROPS Canopy)	3.24 m	10'5"	—	—	—	—	—	—
Overall Length (With S Blade) (Without Blade)	—	—	5.28 m	17'4"	5.69 m	18'8"	5.81 m	19'1"
Width (Over Trunnion)	3.43 m	11'3"	4.19 m	13'9"	4.67 m	15'4"	4.67 m	15'4"
Width (W/O Trunnion — Std. Shoe)	3.14 m	10'3.6"	2.55 m	8'5"	2.54 m	8'4"	2.59 m	8'6"
Ground Clearance	433 mm	17"	347 mm	13.7"	416 mm	16.4"	416 mm	16.4"
Blade Types and Widths:								
Straight	3.99 m	13'1"	3.66 m	12'0"	3.52 m	11'7"	3.32 m	11'7"
Angle	—	—	4.27 m	14'0"	4.50 m	14'9"	4.50 m	14'9"
Angle Straight	—	—	—	—	—	—	—	—
Full Angle	—	—	—	—	—	—	—	—
Universal	—	—	—	—	3.98 m	13'1"	3.98 m	13'1"
Semi-U	—	—	—	—	3.69 m	12'2"	3.69 m	12'2"
Fuel Tank Refill Capacity	383 L	101 U.S. gal	435 L	115 U.S. gal	479 L	127 U.S. gal	479 L	127 U.S. gal

*Operating Weight includes ROPS canopy, operator, lubricants, coolant, full fuel tank, hydraulic controls and fluid, straight dozer with tilt, horn, back-up alarm, retrieval hitch and front pull hook.

— D7G includes end track guiding guards.

**Height (stripped top) — without ROPS canopy, exhaust, seat back or other easily removed encumbrances.

Blade Specifications D6R LPG

Model	S (Straight)	A (Angling)	SU (semi universal)
Blade capacities	3.70 m ³	4.30 m ³	5.62 m ³

Blade Specifications D7G, D7R, D7R XR

Model	S (Straight)	A (Angling)	SU (semi universal)	U (Universal)
Blade capacities	3.89 m ³	5.16 m ³	6.89 m ³	8.34 m ³

D6R LPG
Steering Clutches & Brakes (FTC)

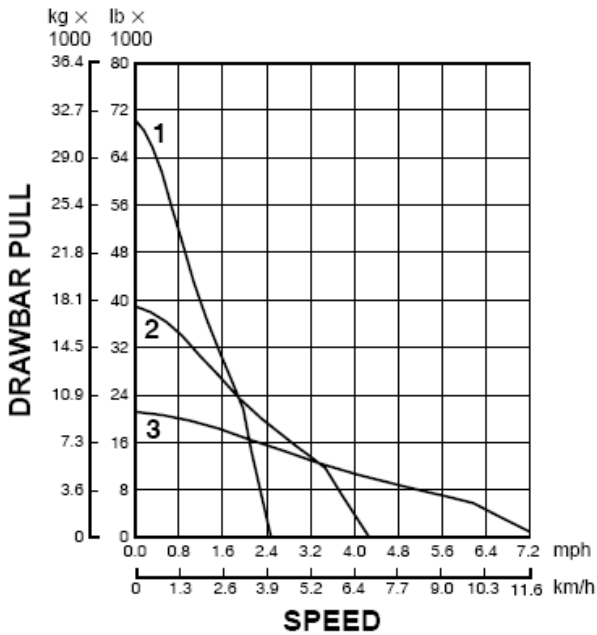

D7G

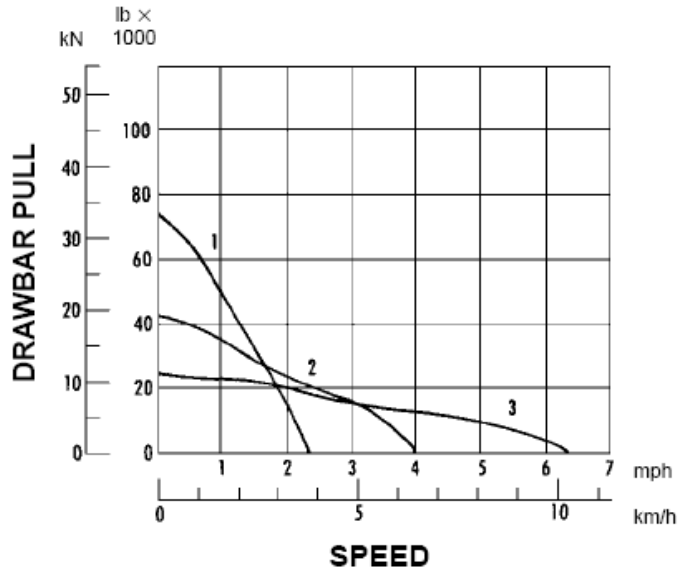

D7R Standard/XR
Steering Clutches & Brakes

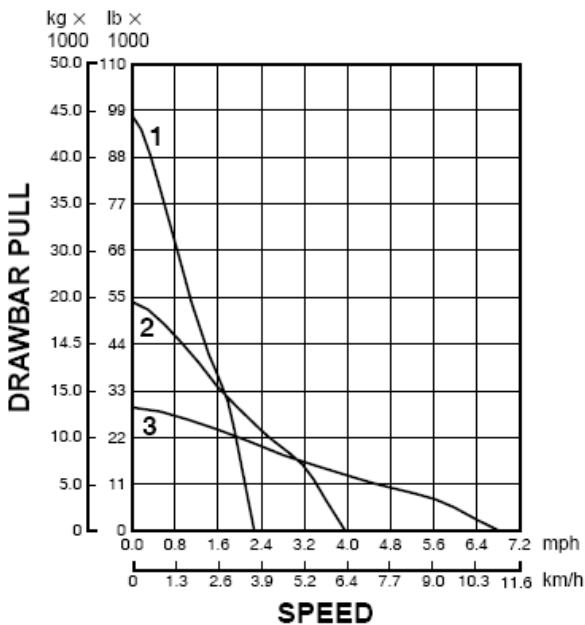

D7R Standard/XR
Differential Steering

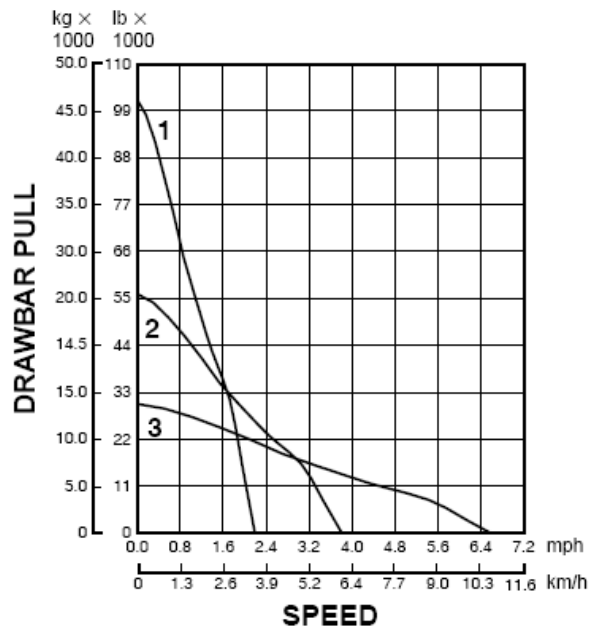

Wheel Loaders | Specifications



MODEL	988G		990 Series II		994D	
Flywheel Power: Net	354 kW	475 hp	486 kW	625 hp	933 kW	1250 hp
Max.	388 kW	520 hp				
Engine Model	3456DITA ATAAC		3412E TA		3516B TA	
Rated Engine RPM	1900		2000		1600	
Bore	140 mm	5.5"	137 mm	5.4"	170 mm	6.69"
Stroke	171 mm	6.75"	152 mm	6"	190 mm	7.48"
No. Cylinders	6		12		16	
Displacement	15.8 L	966 in ³	27 L	1649 in ³	69 L	4221 in ³
Speeds Forward	km/h	mph	km/h	mph	km/h	mph
1st	6.9	4.3	7.2	4.5	7.4	4.6
2nd	12.3	7.6	12.9	8.0	13.2	8.2
3rd	21.8	13.5	22.5	14.0	23.4	14.5
4th	38.7	24.0	—	—	—	—
Speeds Reverse						
1st	7.1	4.4	8.0	5.0	9.2	5.1
2nd	12.6	7.8	14.2	8.8	14.6	9.1
3rd	22.3	13.8	25.0	15.5	25.8	16.0
4th	—	—	—	—	—	—
Hydraulic Cycle Time, Rated Load in Bucket:	Seconds		Seconds		Seconds	
Raise	9.4		9.2		12.5	
Dump	2.4		2.9		3.4	
Lower (Empty, Float Down)	3.8		3.8		4.0	
Total	15.6		15.9		19.9	
Tread Width	2.59 m	8'6"	3.1 m	10'0"	3.9 m	12'10"
Width Over Tires	3.54 m	11'7"	4.1 m	13'6"	5.45 m	17'10"
Ground Clearance	583 mm	23"	507 mm	20"	825 mm	32"
Fuel Tank Capacity	679 L	179 U.S. gal	970 L	252 U.S. gal	4540 L	1200 U.S. gal
Hydraulic Tank Capacity	470 L	124 U.S. gal	174 L	45 U.S. gal	823 L	165 U.S. gal
Hydraulic System Capacity (includes tank)	257 L	68 U.S. gal	435 L	113 U.S. gal	895 L	233 U.S. gal

Bucket capacity 988G	
Model	General Purpose
Heaped capacity	7.0 m ³
Struck capacity	5.9 m ³
Bucket capacity 990 Series II	
Model	General Purpose
Heaped capacity	8.6 m ³
Struck capacity	7.0 m ³
Bucket capacity 994D	
Model	General Purpose
Heaped capacity	8.6 m ³
Struck capacity	7.0 m ³

988G TRAVEL TIME — LOADED

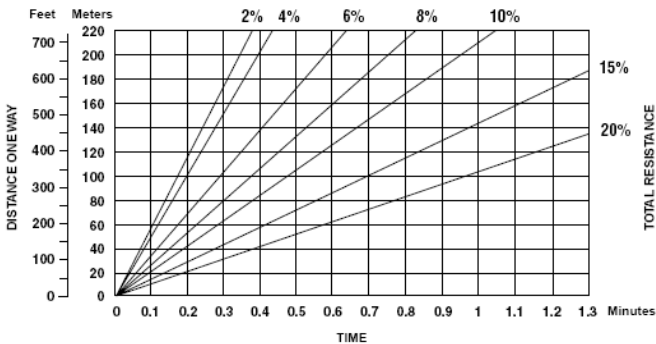

988G TRAVEL TIME — EMPTY

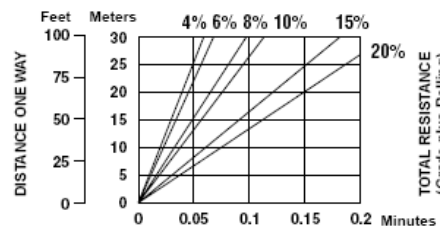
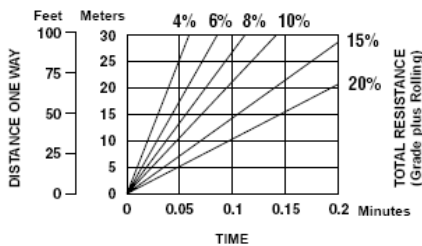
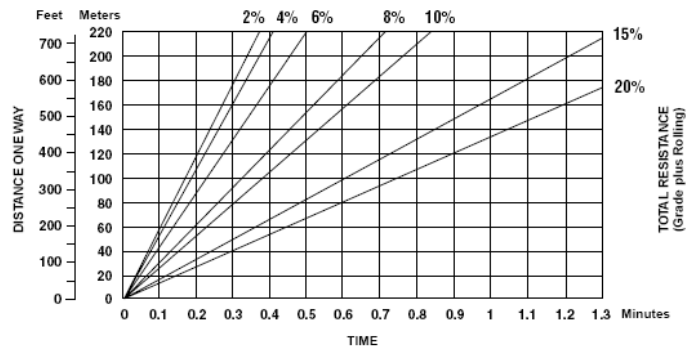

990 SERIES II TRAVEL TIME — LOADED

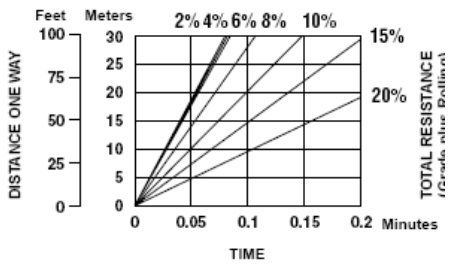
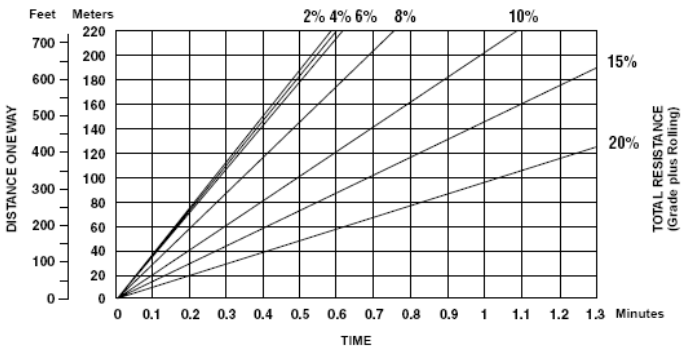

990 SERIES II TRAVEL TIME — EMPTY

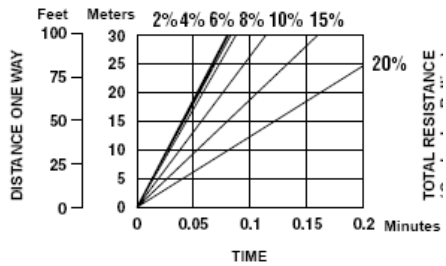
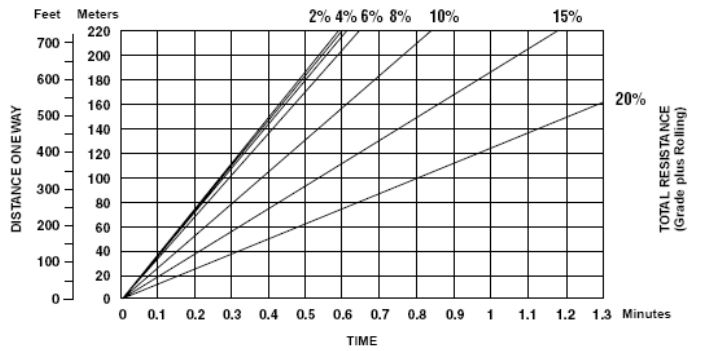

994D TRAVEL TIME — LOADED

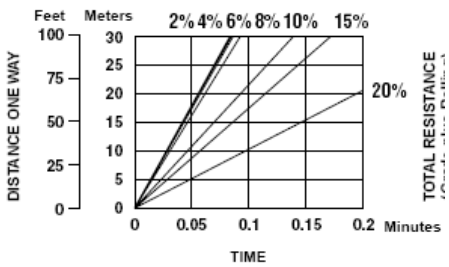
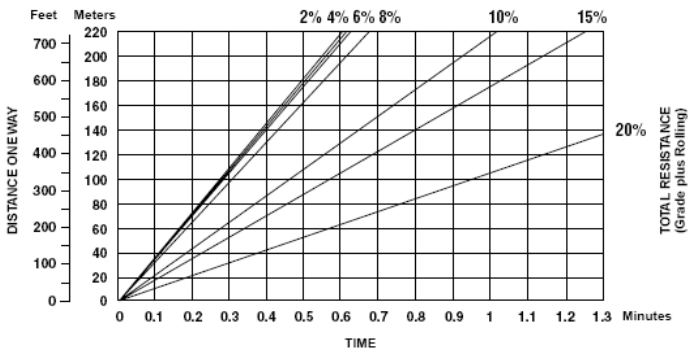

994D TRAVEL TIME — EMPTY

